



Ref: MGR-WRK-ENG./KHI/01/2022  
March 3<sup>rd</sup>, 2022

**TENDER NOTICE**

**CIVIL WORKS - REPLACEMENT OF BROKEN M-S ANGLE, DRAIN PLATES & REPAIR AND EPOXY COATING OF FLOOR AT LINE MAINTENANCE - II (BAY - I, FOKKAR HANGAR) ENGINEERING AREA KAP.**

Seal un-conditional tenders are invited from PIA 'B' class approved enlisted Civil contractors for the subject work. Tender should be addressed to General Manager (Facilities Management) and dropped in Finance Manager Works office (2<sup>nd</sup> floor PIA Head Office Building Karachi) by March 18th, 2022 till 15:00 hrs and will be open on the same day at 15:30 hrs in the office of General Manager Facilities Management. All details regarding the tender can be downloaded from [www.piac.com.pk](http://www.piac.com.pk).

2 % Earnest money of the bid should be attached with the tender.

On the face of envelop reference must be written MGR-WRK-ENG./KHI/01/2022

**GENERAL MANAGER**  
**(FACILITIES MANAGEMENT DIVISION)**  
1<sup>ST</sup> FLOOR, FLIGHT OPERATION BUILDING  
PIA HEAD OFFICE.  
Tel: 021-9904640  
Email: [gm.facilitiesmanagement@piac.aero](mailto:gm.facilitiesmanagement@piac.aero)

COPY TO:

1. FINANCE MANGER(W&P)
2. NOTICE BOARD



**TENDER FORM**

M/s \_\_\_\_\_

Ref: MGR-WRK-ENG./KHI/01/2022  
March 3rd, 2022

**CIVIL WORKS - REPLACEMENT OF BROKEN M-S ANGLE, DRAIN PLATES & FLOOR AT LINE MAINTENANCE - II (BAY - I, FOKKAR HANGAR) ENGINEERING AREA KAP.**

Dear Sir,

Please send not later than **March 18, 2022** you're sealed quotations for the items mentioned in the attached sheet as per following terms and condition.

1. PIA reserves the right to accept or reject any quotations without assigning any reason as per PPRA rules.
2. An earnest-money of **2%** in the shape of pay-order/Bank Draft in favor of PIA is to be attached with quotation as earnest money.
3. Tender will be opened by on **March 18, 2022** at **15:30** Hours by the under signed in presence of the contractors who care to attend.
4. Your quotation should remain valid up to **Three Months**.
5. Period required for completion of project is **Two months**.
6. All works/sample/design will be executed / approved by the engineer on duty.
7. PIA reserves the right to cancel the work order at any stage of the work without assigning any reason as per PPRA RULE # 33.
8. PIA accepts only standard materials of original manufacturer strictly in accordance with the specifications. Any inferior or sub-standard materials, if used, shall be rejected out-rightly and registration of the contractor concerned may be cancelled.
9. PIA shall have the option to increase or decrease the quantity of any item mentioned in the quotation / work order.
10. The firm to whom the contract is awarded shall have to abide by the rules and regulations mentioned in the work order and as well as the all rules & regulations of PIA, PEC and PPRA.
11. No excuse of non – availability of materials of fluctuation in the market rates etc. shall be accepted after the work order is issued.
12. Security deposit 10% will be deducted from each running bill and same will be returned after 01 year. In case of any discrepancy found, the same will be withheld without prior notification.
13. If the work is delayed after given time period, Rs. 2000 / day will be deducted, up to max. 10% of total project cost.
14. The attached Performa of permit to work is mandatory job to be followed at the time of award of work. Annexure 'A'
15. The work will remain under warranty for 01 year during this period if any defects occurred in work will be rectified by contractor at his own risk cost.

Seal & Signature  
Of the contractor

For: **Pakistan International Airlines**



M/s \_\_\_\_\_

Date: \_\_\_\_\_

<b>BOQ CIVIL WORK</b>					
<b>SR. No.</b>	<b>DESCRIPTION</b>	<b>QTY.</b>	<b>UNIT</b>	<b>RAT E</b>	<b>AMOUNT</b>
1	Demolition of existing hard cement concrete or R.C.C Floor up to 6 Inch thick with proper leveling , drilling, cutting, use L-T Machine, mark proper / straight line for proper floor cutting etc as per site requirements, remove all types of Debris from site and dump away from P.I.A premises. Take all safety measures as per site requirements. As desire by Engineer.(as per attached drawing).	630.67	Cft		
2	Providing and laying of cement concrete having ratio (1:1.5:2) cylindrical compressive strength 4000 Psi using aggregate 16 mm to 20 mm size, proper mixing with mixer machine at site and used sweet water for proper bonding as per standard and specification etc. Used Chemical for old and new cement concrete, proper grouting, laying concrete, after pouring of cement concrete required 28 days for curing process, used (Jutes) for proper curing. Take all safety measures at site as per standard etc. Before start work at site, submit laboratory test result of above mentioned ratio. As Desire by Engineer.(as per attached drawing).	630.67	Cft		
3	Supply and fix Channel, Angle or M-S Plate or tee sections, holds fast, straps or flat patti fixed with welding bolts washers, ladders, railing, hard floor etc. complete by welding in lieu of riveting / bolting with popper leveling and cutting etc. (2 coats of painting work (Red Oxide + Oil Paint as per standard) etc. Take All safety Measures as per site requirements. As Desire By Engineer.	1125.75	Kg		
4	Supplying & Applying of Epoxy coat 500 microns as per approved quality and standard, including grinding crack filling with sealant work complete work.(Vendor list is attached).	14126	Sft		

 For: **Pakistan International Airlines**

 Seal & Signature  
 Of the contractor



5	Re sizing of existing M-S Drain plates with gas cutting and proper welding repair, cutting, rubbing, and grinding, buffering, e.t.c as per site requirements. As desire by Engineer.	1	Compete Job		
<b>Total Amount</b>					

- Must be inclusive of all taxes.
- All contractors are advised to ensure prior visit of site before submitting the tender, for assessment of job, but not mandatory.

<b>Vendor List</b>	
<b>Item:4#</b>	<b>Items Description</b>
1.	Kansi Japan, BASF, SIKA Pakistan or equivalent as approved by engineer Incharge.

Seal & Signature  
Of the contractor

For: **Pakistan International Airlines**



## **ANNEXURE 'A'**

## **PERMIT TO WORK**

Seal & Signature  
Of the contractor

For: **Pakistan International Airlines**

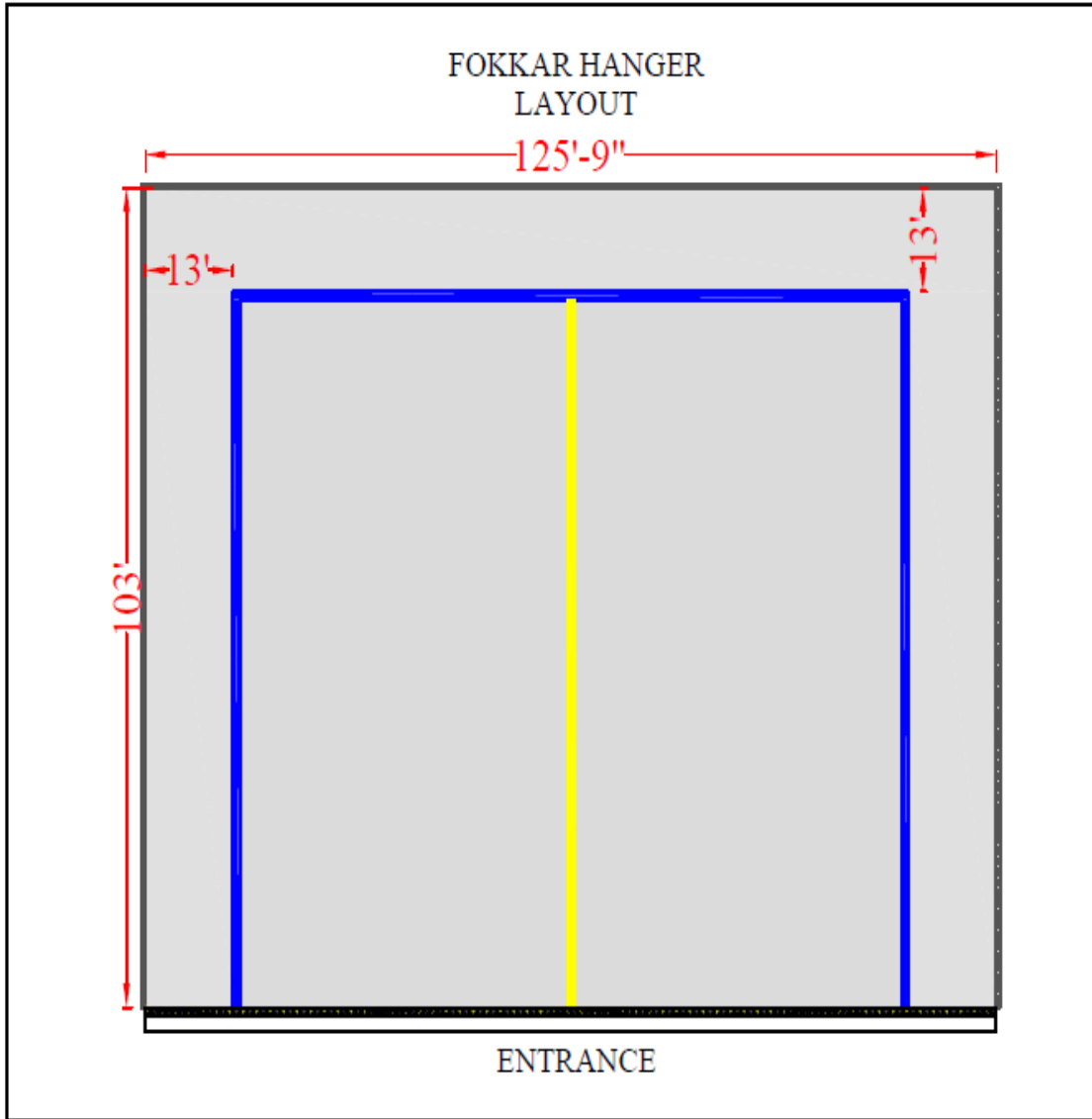

Seal & Signature  
Of the contractor

For: **Pakistan International Airlines**

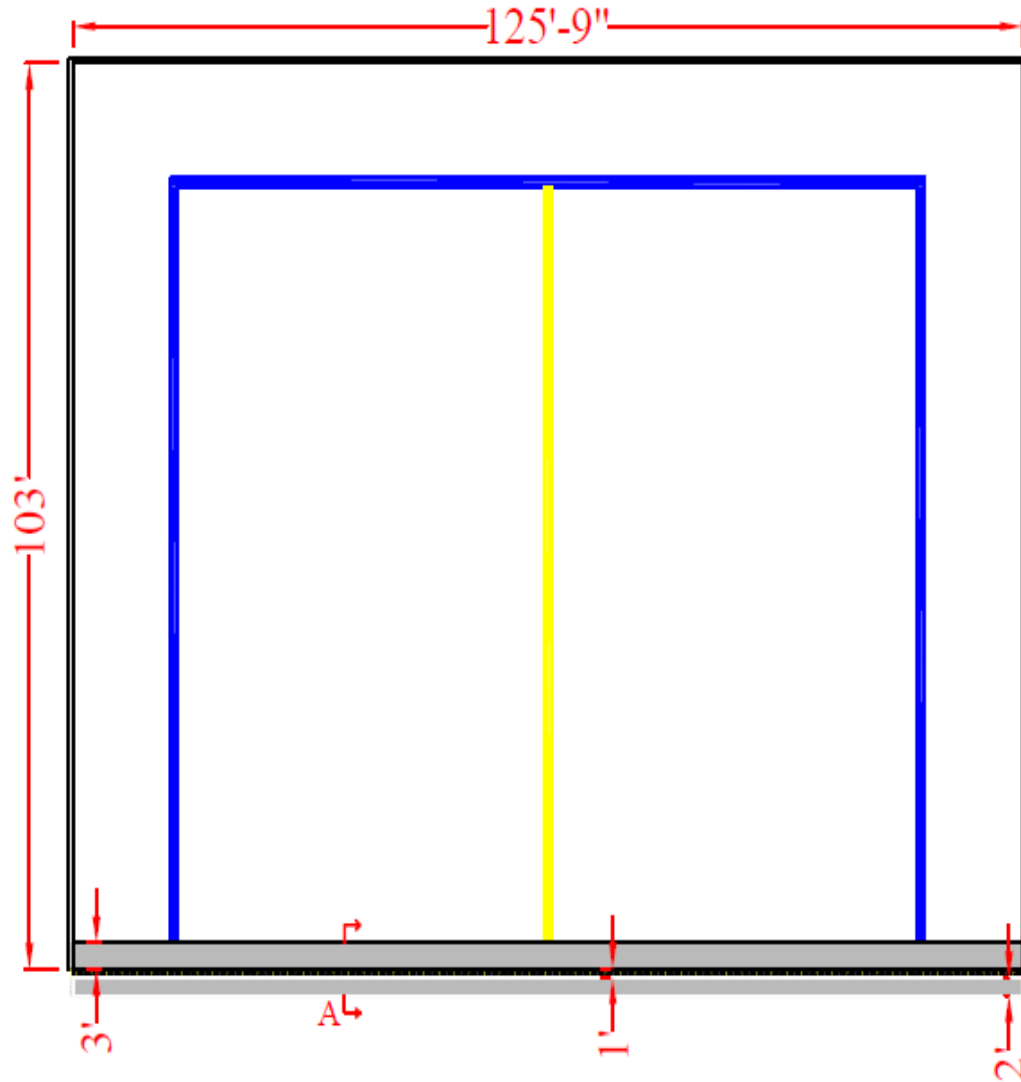

Seal & Signature  
Of the contractor

For: **Pakistan International Airlines**

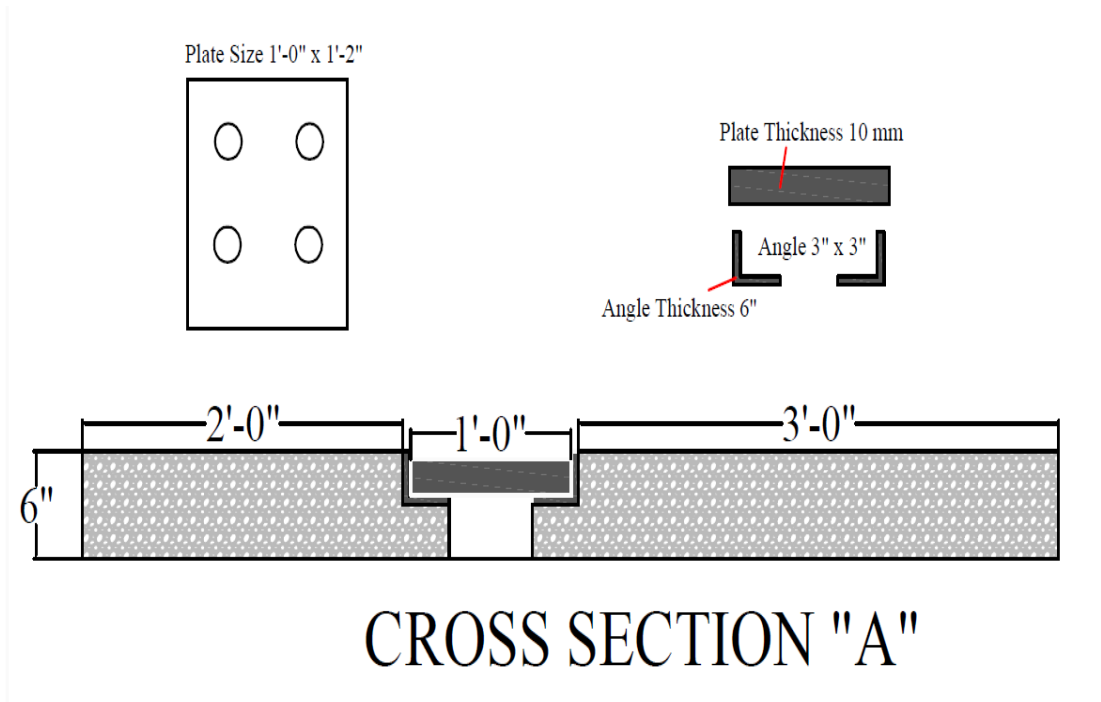

Seal & Signature  
Of the contractor

For: **Pakistan International Airlines**